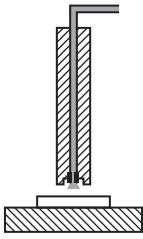
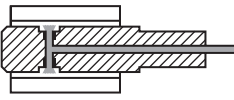
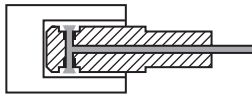
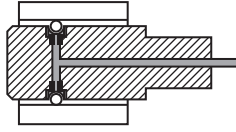
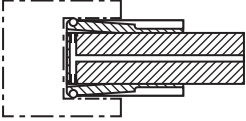
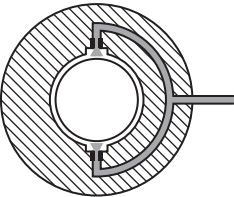
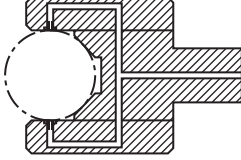
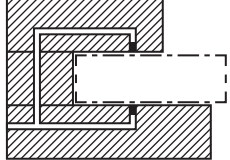
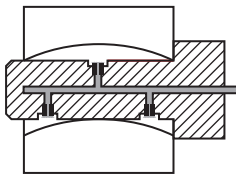
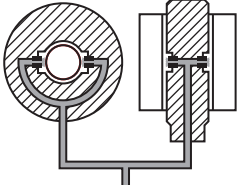
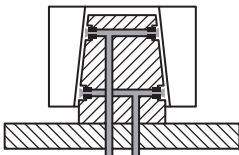
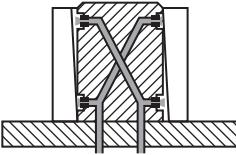
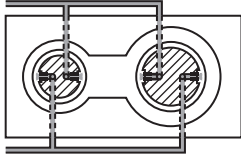
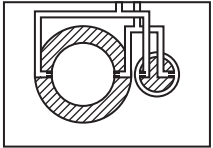
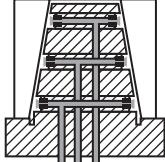
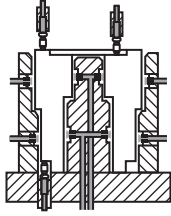

空気マイクロメータ測定例
Measurement examples of Air micrometer

各種の測定ヘッドを用いて下記のような項目の測定ができます。
Measurement as below can be applied by using various measuring heads.

- 
1. 厚さ測定
For thickness
- 
2. 内径測定 (通し穴)
For internal dia. (through hole)
- 
3. 内径測定 (止り穴)
For internal dia. (blind hole)
- 
4. 内径測定 (ボールコンタクト式)
For internal dia. (Ball contact type)
- 
5. 内径測定 (リーフ式)
For internal dia. (plate spring type)
- 
6. 外径測定 (リング式)
For external dia. (Ring type)
- 
7. 外径測定 (挟み式)
For external dia. (Caliper type)
- 
8. 厚さ測定
For thickness
- 
9. 真直度測定
For straightness
- 
10. マッチング (穴と軸のはめあい寸法) 測定
For mating between bore and shaft
- 
11. テーパー測定
For conicity of inner cone
- 
12. 直角度測定
For perpendicularity
- 
13. 芯間距離 (ピッチ) 測定
For spacing between separate cylindrical bores
- 
14. 芯間距離 (ピッチ) 測定 (特殊)
For spacing between separate cylindrical bores (special purpose)
- 
15. テーパー及び基準径測定
For conicity, form & basic diam.
- 
16. 多点測定
For multi-places